



TWO-STAGE, VARIABLE-SPEED

ECM GAS FURNACE

UP TO 96% AFUE

HEATING INPUT: 40,000–120,000 BTU/H

Contents

Nomenclature..... 2
 Accessories 2
 Product Specifications..... 3
 Dimensions 4
 Airflow Specifications 5
 Wiring Diagram..... 6



Standard Features

- Integrated communicating ComfortBridge™ Technology
- Commissioning and diagnostics via on board Bluetooth with the CoolCloud phone and tablet application
- Heavy-duty stainless-steel tubular heat exchanger
- Stainless-steel secondary heat exchanger
- Two-stage gas valve provides quiet, economical heating
- Durable Silicon Nitride igniter
- Quiet two-speed induced draft blower
- Compatible with any single-stage thermostat
- Self-diagnostic control board with constant memory fault code history output to a triple 7-segment display
- Color-coded low-voltage terminals with provisions for electronic air cleaner
- Efficient and quiet variable-speed airflow system gently ramps up or down according to heating or cooling demand
- Multiple continuous fan speed options offer quiet air circulation
- Auto-Comfort and enhanced dehumidification modes available
- All models comply with California 40 ng/J Low NOx emissions standards
- For installation in California’s South Coast Air Quality Management District (SCAQMD) only:
 This furnace does not meet the SCAQMD Rule 1111 14 ng/J NOx emission limit, and thus is subject to a mitigation fee of up to \$450. This furnace is not eligible for the SCAQMD Clean Air Furnace Rebate Program: www.CleanAirFurnaceRebate.com.
- AHRI Certified; ETL Listed

Cabinet Features

- Designed for multi-position installation — downflow, horizontal left or right
- Certified for direct vent (2-pipe) or non-direct vent (1-pipe)
- Convenient left or right connection for gas and electrical service
- Cabinet air leakage ≤ 2%
- Heavy-gauge steel cabinet with durable finish
- Fully insulated heat exchanger and blower section
- Airtight solid bottom or side return with easy-cut tabs for effortless removal in bottom air-inlet applications



* Complete warranty details available from your local dealer or at www.amana-hac.com. To receive the Lifetime Heat Exchanger Limited Warranty, the Lifetime Unit Replacement Limited Warranty (in both cases good for as long as you own your home), and the 10-Year Parts Limited Warranty, online registration must be completed within 60 days of installation. Online registration is not required in California or Québec.

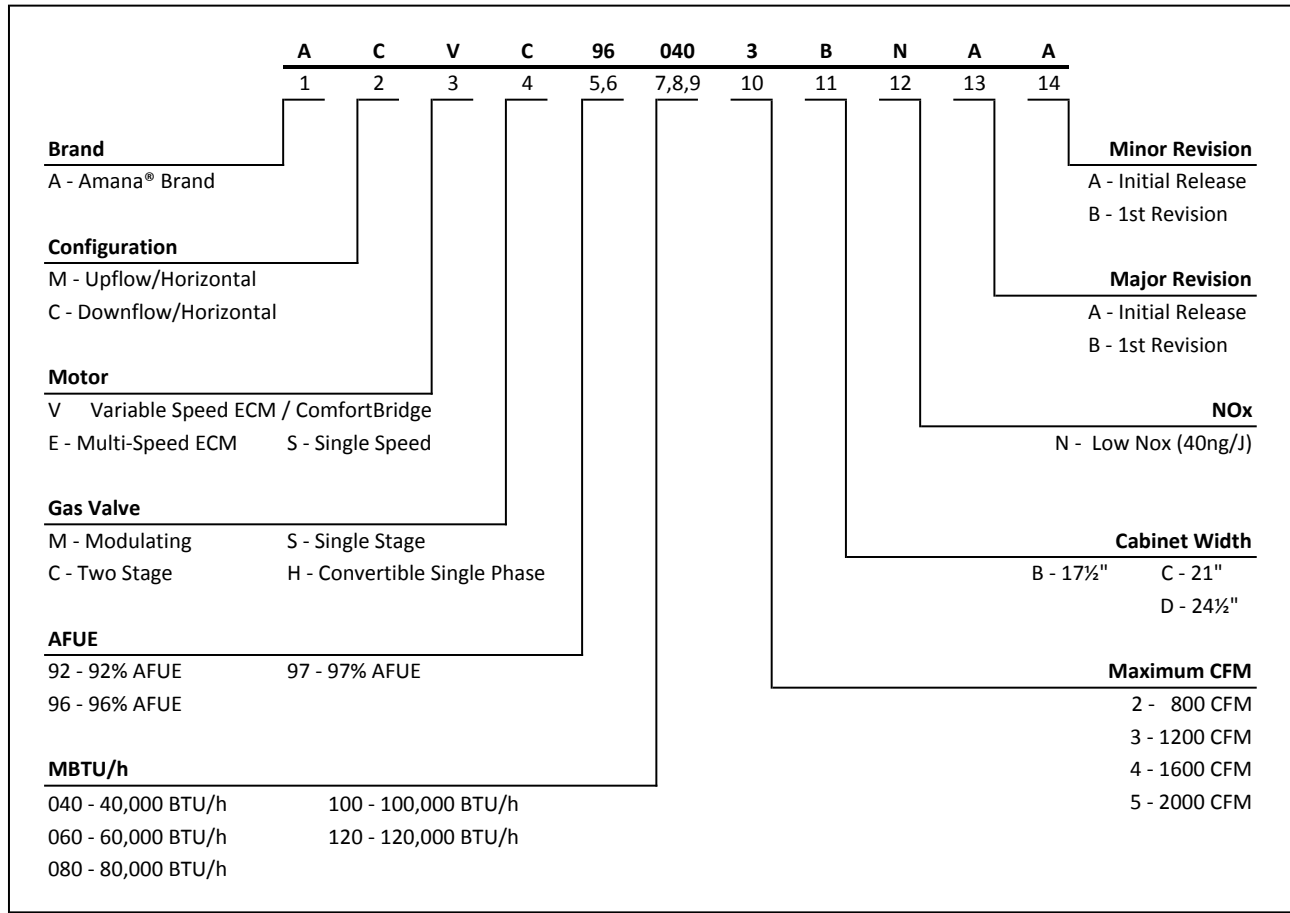

ACCESSORIES

MODEL	DESCRIPTION	ACVC96 0403BNB	ACVC96 0603BNB	ACVC96 0804CNB	ACVC96 1005CNB	ACVC96 1205DNB
CVENT-2	Concentric Vent Kit (2")	√	√	√	√	---
CVENT-3	Concentric Vent Kit (3")	√	√	√	√	√
CFSB17	Downflow Sub-Base 17.5"	√	√	---	---	---
CFSB21	Downflow Sub-Base 21"	---	---	√	√	---
CFSB24	Downflow Sub-Base 24"	---	---	---	---	√
RF000142	Drain Kit -Horizontal Left Vertical Flue	√	√	√	√	√
0170K00000S	Flush Mount Vent Kit - 3" or 2"	√	√	√	√	√
0170K00001S	Flush Mount Vent Kit - 2"	√	√	√	√	---
HASFK	High-Altitude Natural Gas Kit	HASFK-1	HASFK-1	HASFK-2	HASFK-3	HASFK-3
HASFK	High-Altitude LP Gas Kit	HASFK-1	HASFK-1	HASFK-2	HASFK-2	HASFK-3
LPLP03	Low LP Gas Pressure Switch	√	√	√	√	√
LPM-08	LP Conversion Kits	√	√	√	√	√

	ACVC96 0403BNB	ACVC96 0603BNB	ACVC96 0804CNB	ACVC96 1005CNB	ACVC96 1205DNB
HEATING DATA					
High Fire Input ¹	40,000	60,000	80,000	100,000	120,000
High Fire Output ¹	38,400	57,600	76,800	96,000	115,200
Low-Fire Steady-State Input ¹	28,000	42,000	56,000	70,000	84,000
Low-Fire Steady-State Output ¹	26,880	40,320	53,760	67,200	80,640
AFUE ²	96	96	96	96	96
Temperature Rise Range (°F)	35 - 65	20 - 50	25 - 55	35 - 65	35 - 65
Vent Diameter ³	2" - 3"	2" - 3"	2" - 3"	2" - 3"	2" - 3"
No. of Burners	2	3	4	5	6
CIRCULATOR BLOWER					
Available AC @ 0.5" ESP	1.5 - 3	1.5 - 3	1.5 - 4	2 - 5	2 - 5
Size (D x W)	10" x 8"	11" x 8"	11" x 10"	11" x 10"	11" x 11"
Horsepower @ 1075 RPM	½	½	¾	1	1
Speed	VS ECM	VS ECM	VS ECM	VS ECM	VS ECM
ELECTRICAL DATA					
Min. Circuit Ampacity ⁴	7.8	7.8	10.6	14.4	14.4
Max. Overcurrent Device (amps) ⁵	15	15	15	20	20
SHIPPING WEIGHT (LBS)	116	119	143	145	158

¹ Natural Gas BTU/h

² DOE AFUE based upon Isolated Combustion System (ICS)

³ Installer must supply one or two PVC pipes: one for combustion air (optional) and one for the flue outlet (required).
Vent pipe must be either 2" or 3" in diameter, depending upon furnace input, number of elbows, length of run and installation (1 or 2 pipes). The optional Combustion Air Pipe is dependent on installation/code requirements and must be 2" or 3" diameter PVC.

⁴ Minimum Circuit Ampacity = (1.25 x Circulator Blower Amps) + ID Blower amps. Wire size should be determined in accordance with National Electrical Codes. Extensive wire runs will require larger wire sizes.

⁵ Maximum Overcurrent Protection Device refers to maximum recommended fuse or circuit breaker size. May use fuses or HACR-type circuit breakers of the same size as noted.

NOTES

- All furnaces are manufactured for use on 115 VAC, 60 Hz, single-phase electrical supply.
- Gas Service Connection ½" FPT
- Important: Size fuses and wires properly and make electrical connections in accordance with the National Electrical Code and/or all existing local codes.
- For bottom return: Failure to unfold flanges may reduce airflow by up to 18%. This could result in performance and noise issues.
- For servicing or cleaning, a 24" front clearance is required. Unit connections (electrical, flue and drain) may necessitate greater clearances than the minimum clearances listed above. In all cases, accessibility clearance must take precedence over clearances from the enclosure where accessibility clearances are greater.

DIMENSIONS

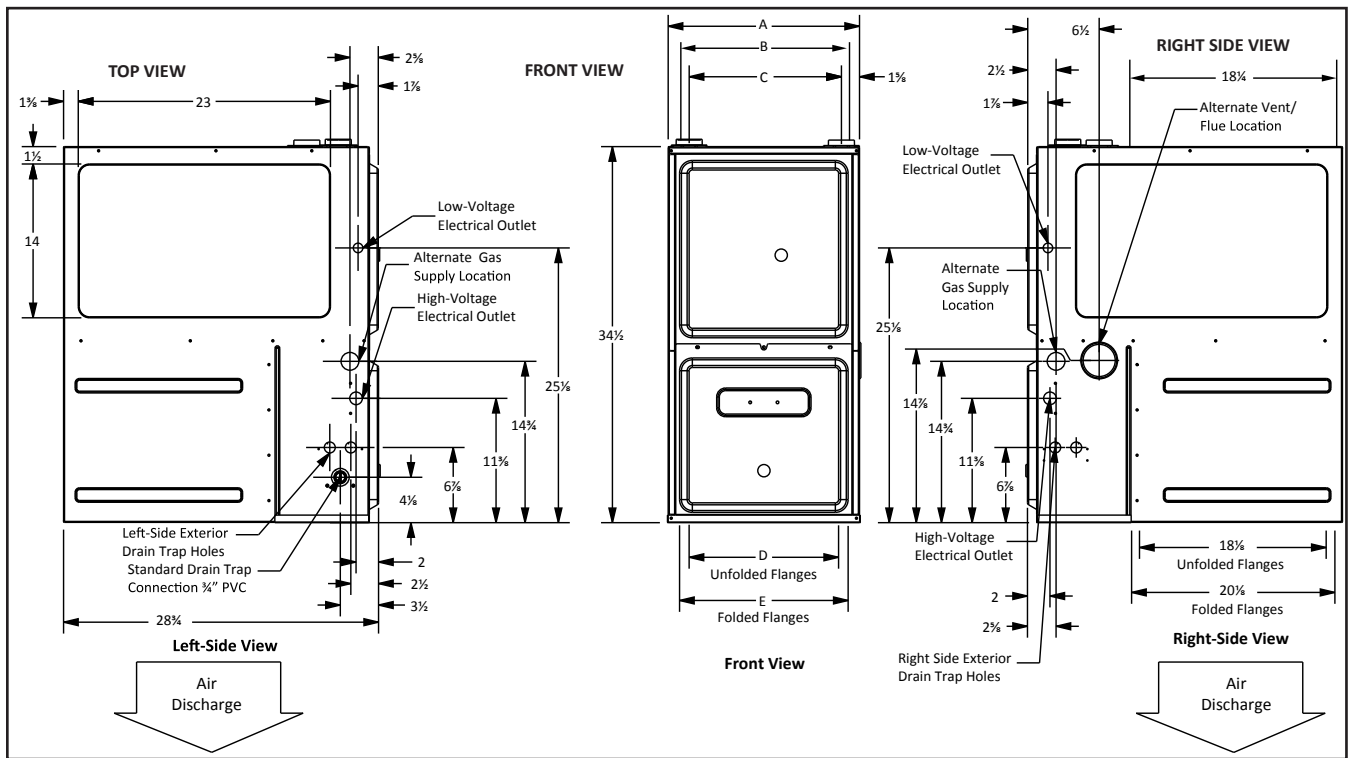

MODEL	AIR RETURN			AIR DISCHARGE	
	A	B	C	D	E
ACVC960403BNB	17½"	14⅝"	14"	14½"	16"
ACVC960603BNB	17½"	14⅝"	14"	14½"	16"
ACVC960804CNB	21"	18⅝"	17½"	18"	19½"
ACVC961005CNB	21"	18⅝"	17½"	18"	19½"
ACVC961205DNB	24½"	21⅝"	21"	21½"	23"

MINIMUM CLEARANCES TO COMBUSTIBLE MATERIALS

POSITION	SIDES	REAR	FRONT	BOTTOM	FLUE	TOP
Downflow	0"	0"	3"	NC	0"	1"
Horizontal	6"	0"	3"	C	0"	6"

C = If placed on combustible floor, the floor MUST be wood ONLY.

NC = For installation on non-combustible floors only. A combustible floor sub-base must be used for installations on combustible flooring.

MINIMUM FILTER SIZES

	ACVC96 0403BNB	ACVC96 0603BNB	ACVC96 0804CNB	ACVC96 1005CNB	ACVC96 1205DNB
Filter Size (in ²) (Qty)	(2) 10 x 20 or (1) 16 x 25 (top return)			(1) 14 x 20 (bottom) or (1) 20 x 25 (top return)	

Note: Other size filters of equal or greater dimensions may be used. Filters may also be centrally located.

MODEL/TEMP RISE RANGE (MID RISE)	ACVC960403BNB* 35-65 (50)		ACVC960603BNB* 20-50 (35)		ACVC960804CNB* 25-55 (40)		ACVC961005CNB* 35-65 (50)		ACVC961205DNB* 35-65 (50)	
	CFM	RISE	CFM	RISE	CFM	RISE	CFM	RISE	CFM	RISE
Recommended cfm for high heat / expected temperature rise	710	50	1400	38	1760	40	1770	50	2150	50
Lowest recommended cfm for hi heat / expected temperature rise	548	65	1072	50	1290	55	1360	65	1650	65
Maximum cfm for hi heat / expected temperature rise	1010	35	1400	38	1760	40	2200	40	2200	48

NOTE: Low Heat CFM = High Heat CFM X .7. Low Heat Temperature Rise Is Expected to Equal High Heat Temperature Rise ± 5%
0140F02402-A

ACVC960403BNB*
COOLING SPEED
(@ .1" - .8" w.c. ESP)

TONS	HIGH-STAGE	LOW-STAGE CFM
1.5	600	420
2	800	560
2.5	1,000	700
3	1,200	840
MAX	1,400	

ACVC960603BNB*
COOLING SPEED
(@ .1" - .8" w.c. ESP)

TONS	HIGH-STAGE	LOW-STAGE CFM
1.5	600	420
2	800	560
2.5	1,000	700
3	1,200	840
MAX	1,400	

ACVC960804CNB*
COOLING SPEED
(@ .1" - .8" w.c. ESP)

TONS	HIGH-STAGE	LOW-STAGE CFM
2	800	560
2.5	1,000	700
3	1,200	840
4	1,600	1120
MAX	1,760	

ACVC961005CNB*
COOLING SPEED
(@ .1" - .8" w.c. ESP)

TONS	HIGH-STAGE	LOW-STAGE CFM
2	800	560
3	1,200	840
4	1,600	1,120
5	2,000	1,400
MAX	2,200	

ACVC961205DNB*
COOLING SPEED
(@ .1" - .8" w.c. ESP)

TONS	HIGH-STAGE	LOW-STAGE CFM
2	800	560
3	1,200	840
4	1,600	1,120
5	2,000	1,400
MAX	2,200	

All furnaces ship as high speed for cooling. Installer must adjust blower speed as needed.
For most jobs, about 400 CFM per ton when cooling is desirable.
Do not operate above .5" w.c. ESP in heating mode. Operating CFM between .5" and .8" w.c. is tabulated for cooling purposes only.

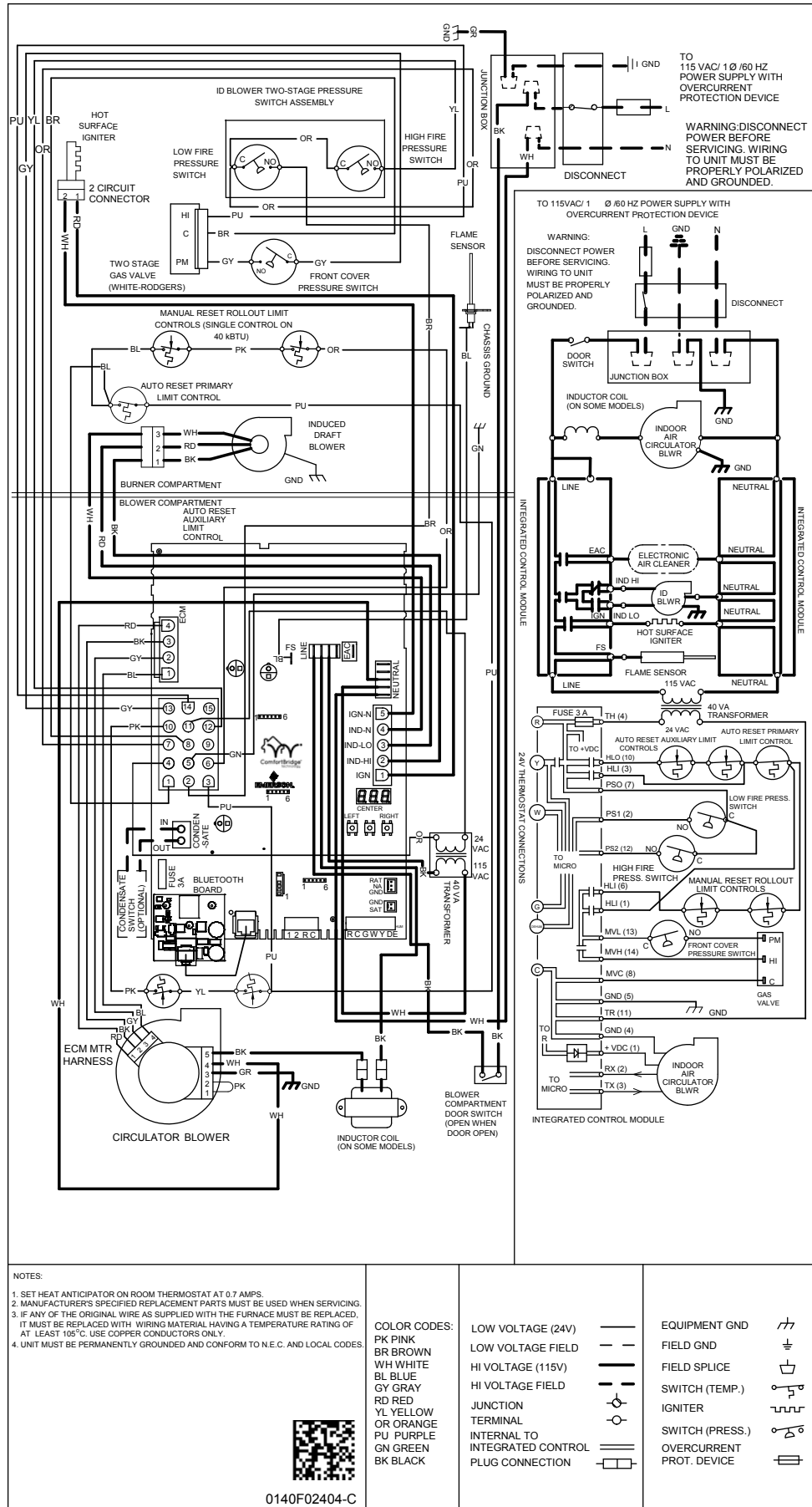

WARNING
 High Voltage: Disconnect all power before servicing or installing this unit. Multiple power sources may be present. Failure to do so may cause property damage, personal injury, or death.

Wiring is subject to change. Always refer to the wiring diagram on the unit for the most up-to-date wiring.